



XL JOINERY LTD

LA PORTE VISTA

MODULAR 3

2090mm High x 4687mm Wide

ASSEMBLY INSTRUCTIONS

READ AND UNDERSTAND THESE INSTRUCTIONS FULLY PRIOR TO STARTING INSTALLATION. IT IS STRONGLY RECOMMENDED THAT A COMPETENT TRADESPERSON INSTALLS THIS PRODUCT.

CONTENTS

Check that all the components listed below are present and in good condition prior to treating and assembling the product.

TIMBER COMPONENTS

MODULAR 3

Frame Timber/ Aluminium Hybrid Sill x 1
Size: 4687 x 200 x 57mm (maximum dimension)

Bolted Door Panels x 4
Size: 1953 x 762 x 54mm

Frame Head x1
Size: 4687 x 158 x 115mm (maximum dimension)

Locking Door Panel x1
Size: 1953 x 762 x 54mm

Frame Head Drip Bead x 1
Size: 4687 x 27 x 20mm (maximum dimension)

Bolted Door Panel Keep x 1
Size: 1953 x 762 x 54mm

Frame Jambs x 2
Size: 2033 x 158 x 67mm (maximum dimension)

HARDWARE COMPONENTS

Intermediate Carrier Set x 2

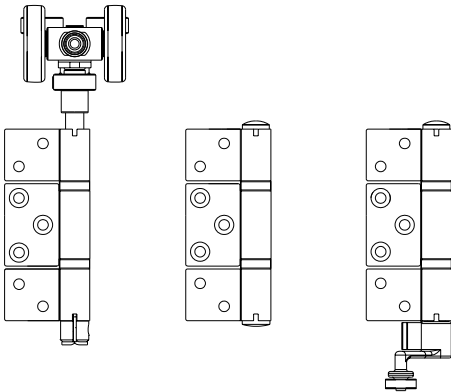

Concealed Pivot Set x 2

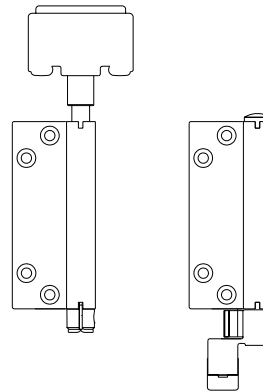

Half Offset Hinge Set x 2

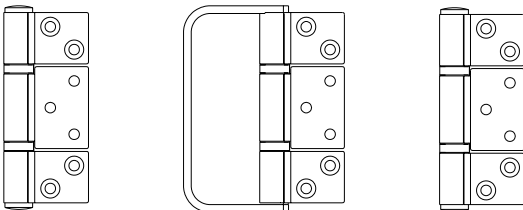

Wall Pivot Set x 2

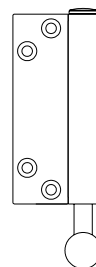

Keyed Drop Bolt x 5

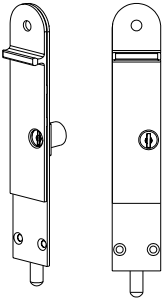

Drop Bolt Keeper x 5

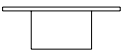

**Non-Keyed Drop Bolt x 5
(Includes striker plates)**

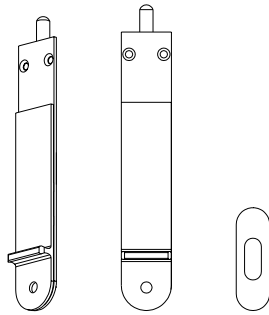

**Aquamac 21 Weather Seal:
2 x 2 metres
2 x 4.75 metres**



**Aquamac 63 Weather Seal:
10 x 2 metres**

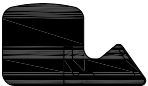

Sill End Caps x 2 (1 Left Hand & 1 Right Hand)

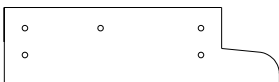
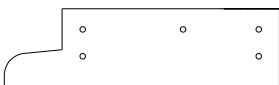

**Multi-Point Lock x 1,
One Piece Lock Keep x 1
One Piece Blank Keep x 2**

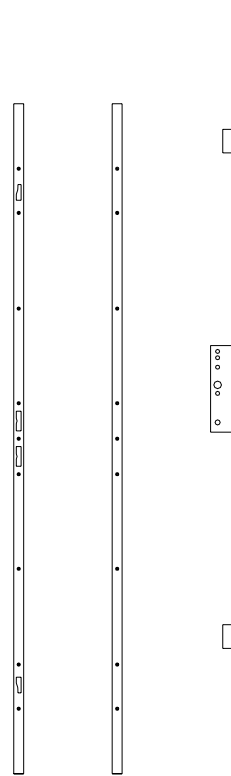

Door Handle Set x 1

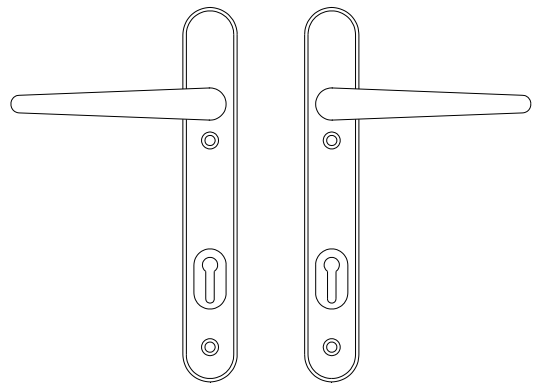

Fixing Screws

18mm Sill End Cap Fixing Screws x 10

63.5mm Sill Frame Assembly Screws x 4

75mm Head Frame Assembly Screws x 4

30mm Round Head Top Track Fixing
Screws x 30

30mm Lock and Keep fixing Screws x 50

STAINING/ PAINTING OF TIMBER COMPONENTS.

Prior to assembling the components it is important to treat the timber elements with a good quality, exterior grade paint or high performance wood stain.

- Ensure that the timber is clean and perform any sanding that may be necessary prior to treatment.
- Apply at least 3 coats of the selected treatment to all faces, edges and hardware cut-outs. Ensure that the treatment is also applied to the top and bottom door edges and the end grain of the frame components.
- It is recommended that the back edges of the frame components, where they will be in contact with the brickwork, are treated with a fourth treatment coating.
- Once installed, periodically check the finishing treatment and touch up as necessary. To ensure the long life and appearance of the La Porte Vista, re-treat the assembly every few years. Refer to the stain or paint manufacturers recommendations for frequency of treatment for specific products.

PREPARING THE OPENING

The brickwork opening should be approximately 10mm wider than the assembled frame dimensions. The brickwork must be level and the opening square prior to installing the frame. Failure to do so may result in the frame being out of square which will impede the proper functioning of the doors.

FRAME DIMENSIONS



BRICKWORK OPENING

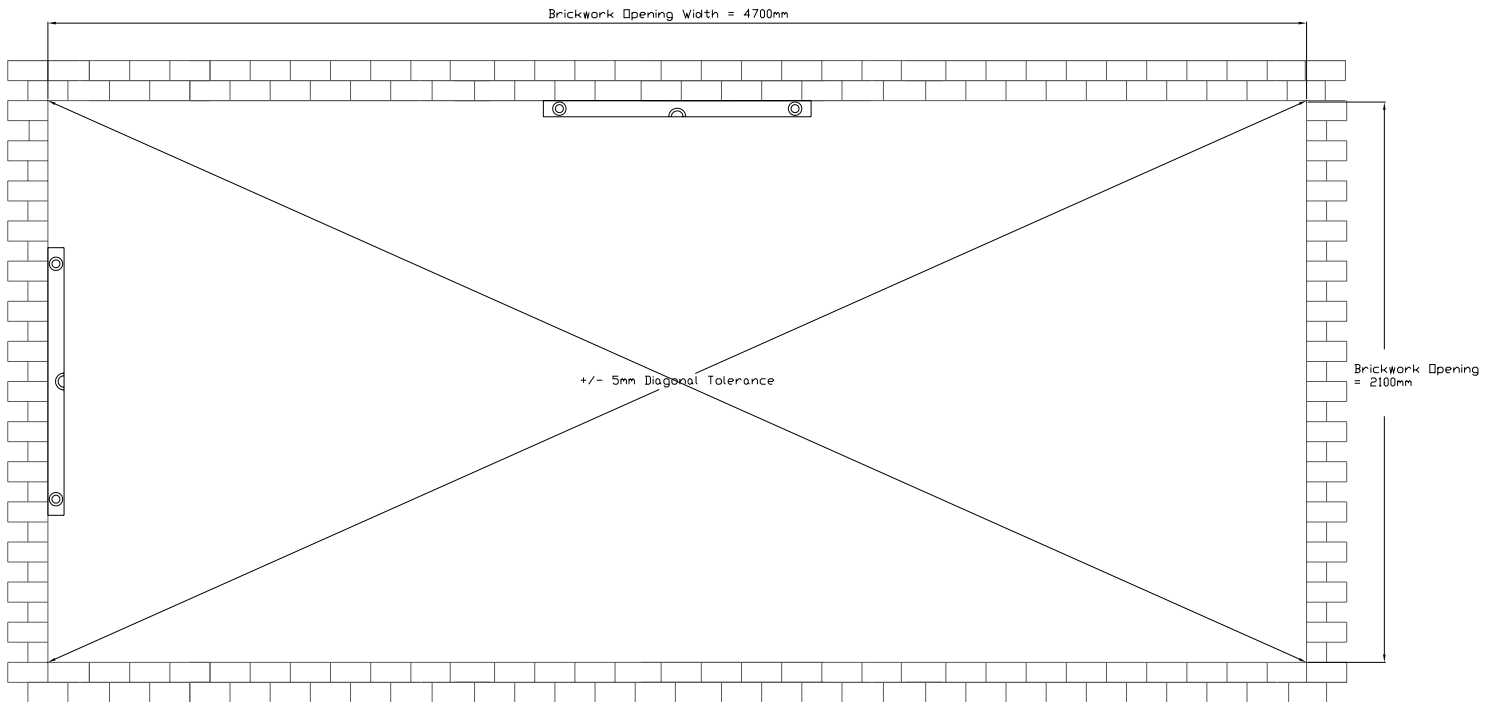

ASSEMBLING THE FRAME

The frame components are pre-drilled to accept the screws provided.

- Apply silicone to the joining surfaces between the jambs and the sill and head components just prior to screwing the jointed components together.
- Use the 63.5mm Sill Frame Assembly Screws to connect the left and right hand jambs to the sill, through the pre-drilled holes. (See Drawing Below).
- Use the 75mm Head Assembly Screws to connect the left and right hand jambs to the head, through the pre-drilled holes. (See Drawing Below).
- Apply silicone between the Sill End Caps and sill and fix the end cap into the sill end using the 18mm Sill End Cap Fixing Screws. Pre-drill the screw holes using a 3mm wood bit.
- The Sill End Caps are handed and the countersunk screw holes must face to the outside of the sill end. Ensure the bottom edge of the Sill End Caps line up with the bottom of the sill.
- Ensure the frame joints are tight and that the frame is square prior to installation.
- Wipe off any excess silicone with a clean cloth.

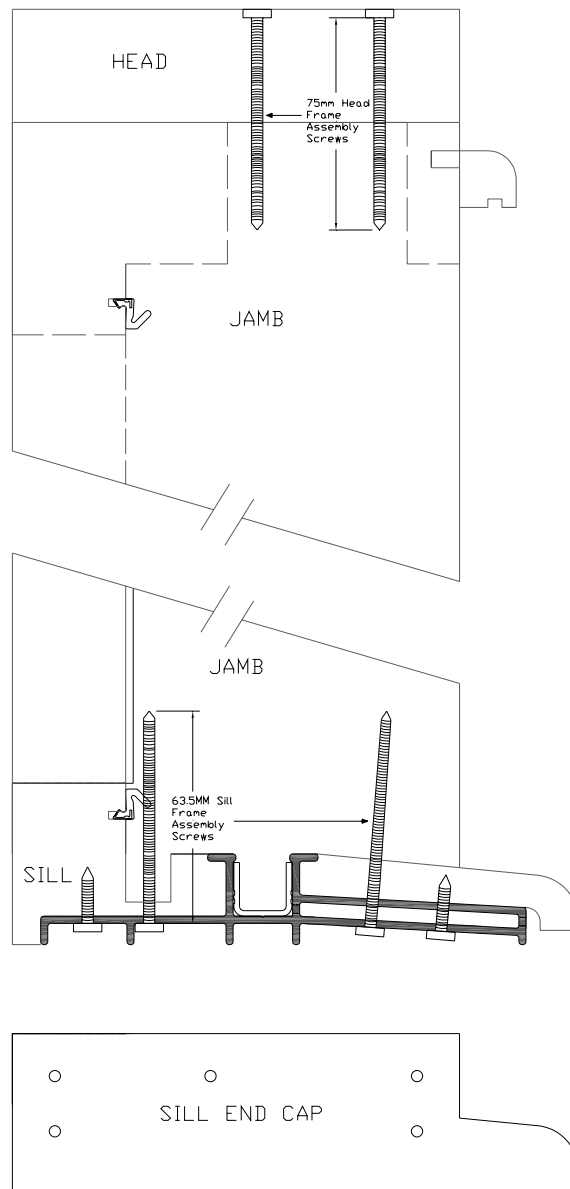

INSTALL THE ASSEMBLED FRAME

- Fit the frame into the brickwork with the sill facing to the outside of the building, ensuring that the frame overhangs the brickwork cavity.
- Situate the sill on a continuous bed of silicone and mortar. (See next page for drawing).
- Ensure the frame is fitted square and level in both the horizontal and vertical plane. If necessary, use packers between the frame and brickwork opening.
- Check that the frame diagonal tolerance is 2mm or less.
- Fit the frame through the jambs and into the brickwork using heavy duty frame fixings, (M10 x 130mm frame fixings recommended, not supplied). Countersink the frame fixings so that they are below the surface of the frame.
- Remove the 2 two carrier screws that hold the Aluminium Top Track in place and place the track carefully to one side for later reattachment.
- Fit the frame through the Frame Head and into the lintel using suitable fixings dependent on lintel type.

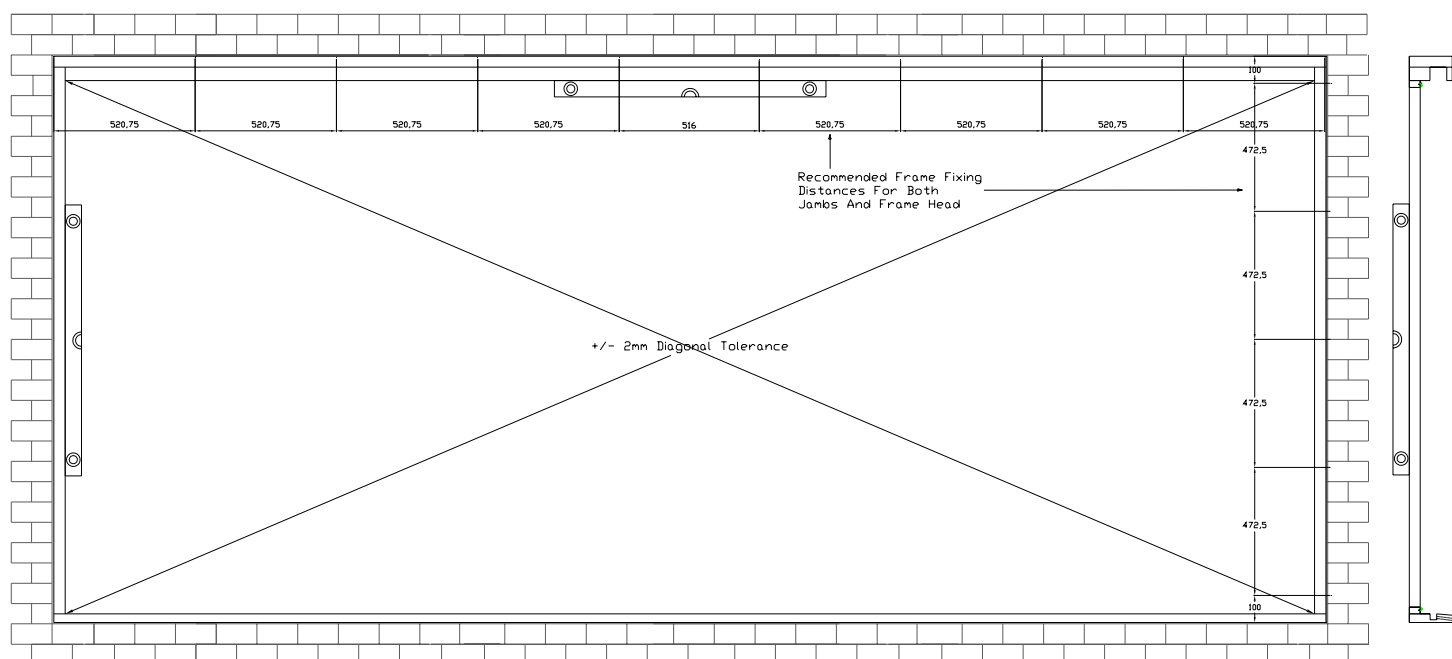

NOTE: It is advised not to fix the frame through the sill as this may damage the sill drainage system: However, if required the sill can be fixed through the deepest part of frame for added stability.

This hardware system is designed to be “Top Hung”; therefore the weight of the doors will be carried by the Aluminium Top Track. As such it is necessary to ensure that there are secure fixings through the Frame Head into the lintel. Failure to do so may result in the Frame Head bowing which will adversely affect the functioning of the hardware system.

INSTALL THE ASSEMBLED FRAME

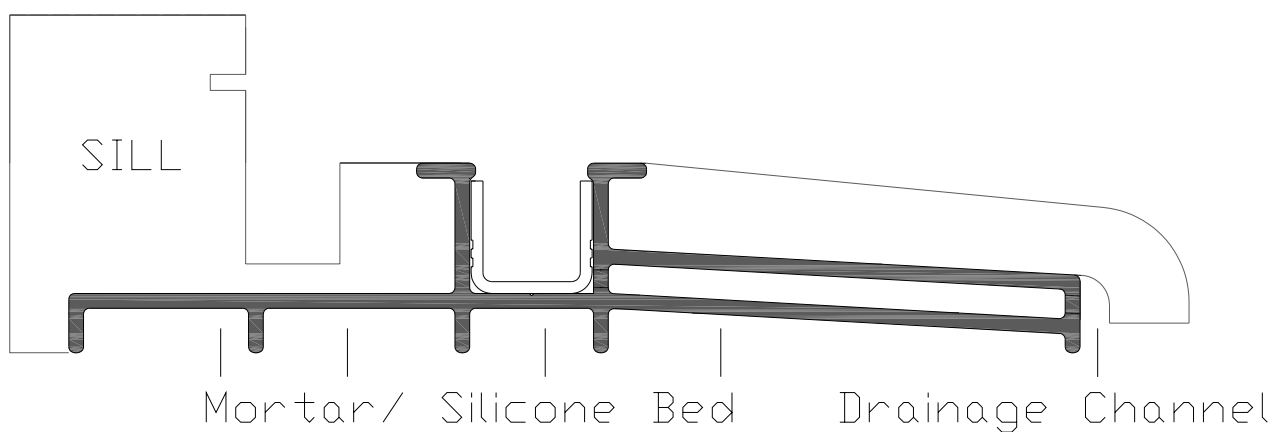

DETERMINE LOCKING DOOR ORIENTATION

The La Porte Vista Modular 3 Set has 6 panels with 3 folding to each side of the frame. The Locking Door Panel can be left or right hand opening and will always open outwards from the building. The hardware arrangement is identical for either option except for the location of the Multi-point Lock and Keep.

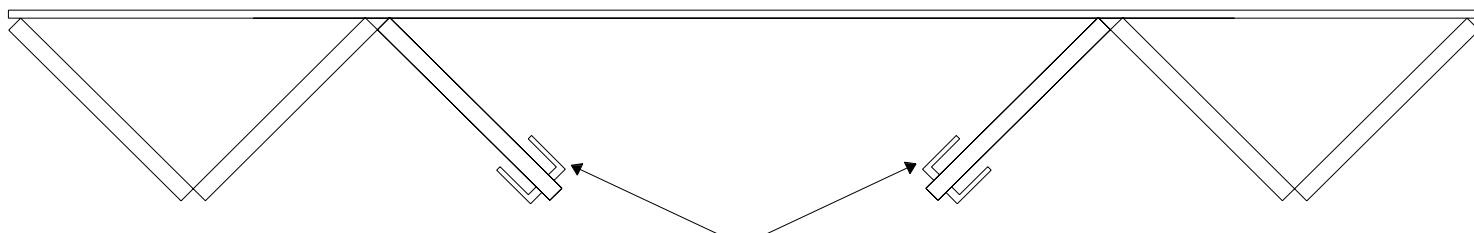

Handles Can Be Located On The Left OR Right Hand Door. The Handles & Multi-Point Lock Must Be Fitted To The Locking Door Panel.

PRE-DRILL THE HINGES

- Pre-drill the hinges using a 4mm wood drill bit ensuring that the hardware configuration matches the drawing below, (do not fix hinges at this stage). Ensure that the holes are drilled into the correct door panels as indicated below.

IMPORTANT: Ensure that the Drop Bolt cut-outs of the Bolted Door Panels and the pinned glazing beads of the Locking Door Panel face to the inside of the building once located in the frame.

- Ensure that there is a 1mm gap between the hinge barrel and the face of the door panels when locating the hinge pilot holes: This will prevent the doors binding after the hinges are fitted, (See below).
- The undrilled door panel edges will need pre-drilling during the actual hanging of the door panels.

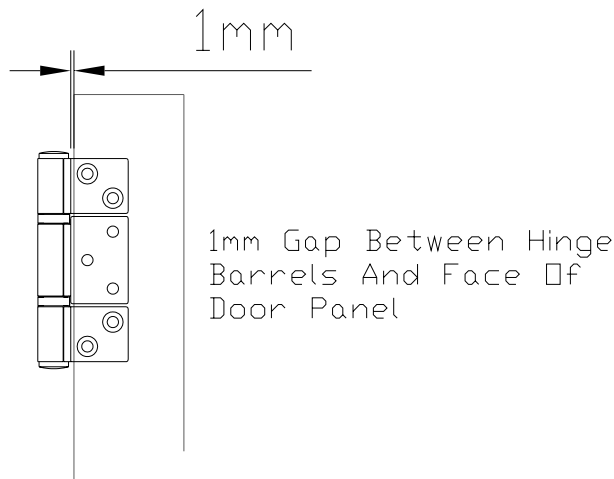
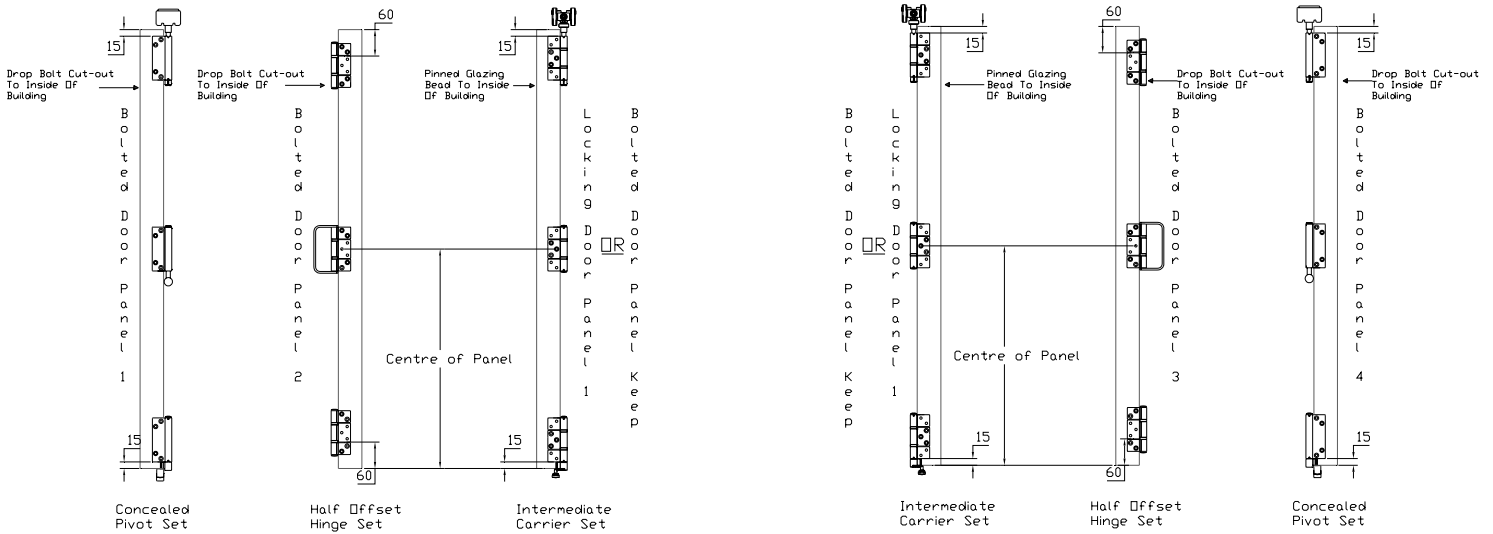
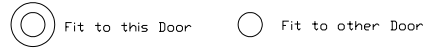

PERMANENT FITTING OF THE TOP TRACK

The Aluminium Top Track will require permanent fixing into the Frame Head at regular intervals as displayed below. At this stage the Aluminium Top Track will have been removed from the Frame Head during the installation of the assembled frame. Drill 4mm pilot holes through the Aluminium Top Track at the designated spacing's. Do not fix the Aluminium Top Track at this stage.

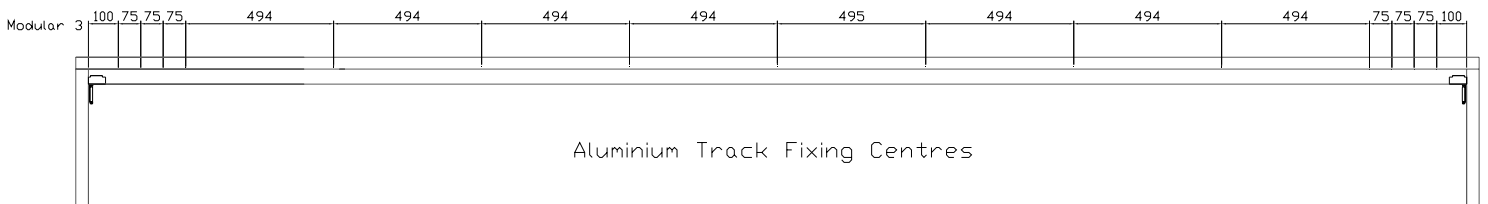
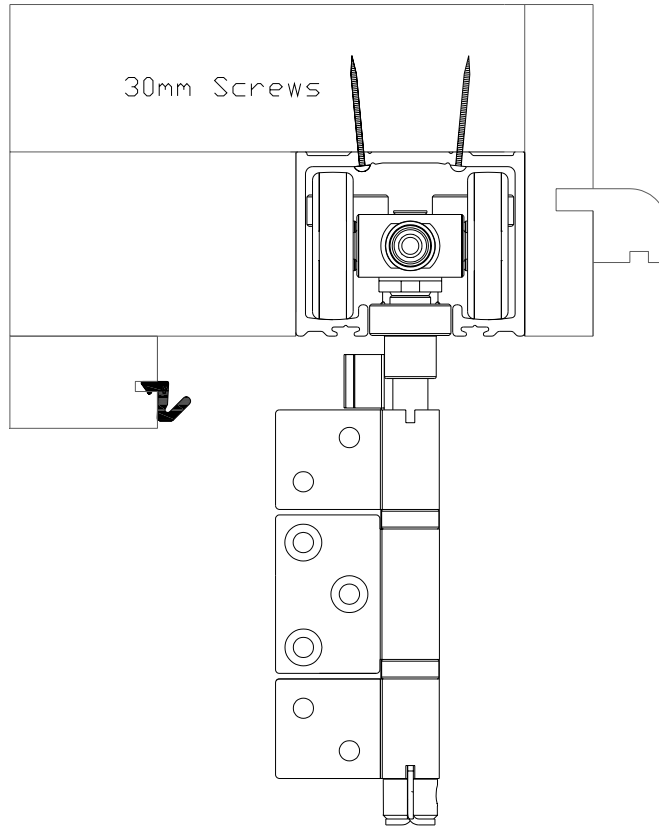

TOP TRACK ASSEMBLY

- Insert the Intermediate Carriers through the Access Slots and into the track. **(Must be done first)**
- The Top Pivot Blocks may need the hinge oriented to suit the opening.

This is achieved as follows:

1. Remove the security grub screw from the top of the pivot block.
2. Remove the hinge by unscrewing the central hinge pin from the pivot block.
3. Remove the hinge from central hinge pin and, rotate it 180° and slide the hinge back onto the central hinge pin.
4. Reattach the central hinge pin to the pivot block and screw the security grub screw back in place.

- Fit the Top Pivot Block into the Aluminium Top Track Access Slot. Secure the Top Pivot Block through the four holes with the 25mm screws provided.
- Repeat with the opposite Top Pivot Block.
- Permanently fix the Aluminium Top Track into place with the 30mm round headed screws provided through the pre-drilled holes.

The Top Pivot Block position can be adjusted by rotating the Horizontal Adjustment Screw, (See **FIT BOLTED DOOR PANEL 1**)

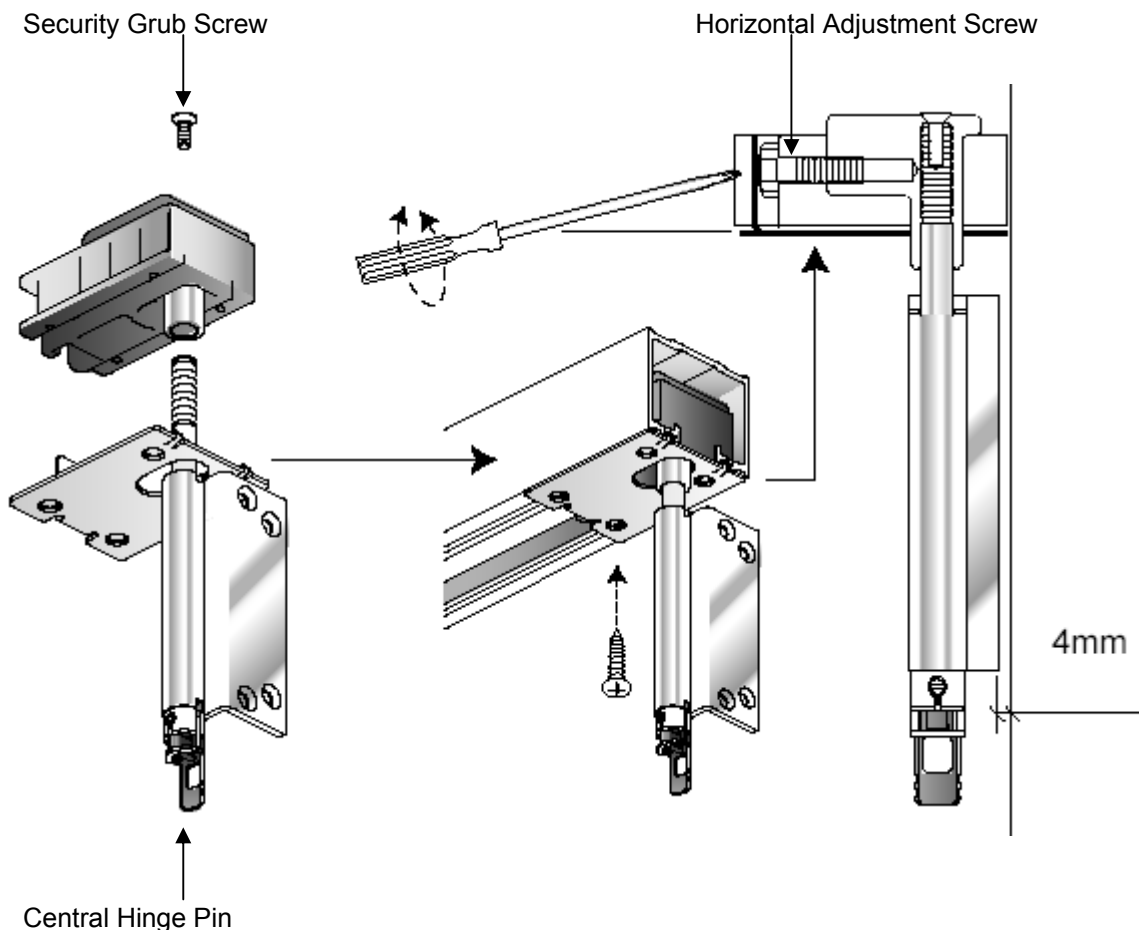

TOP TRACK ASSEMBLY

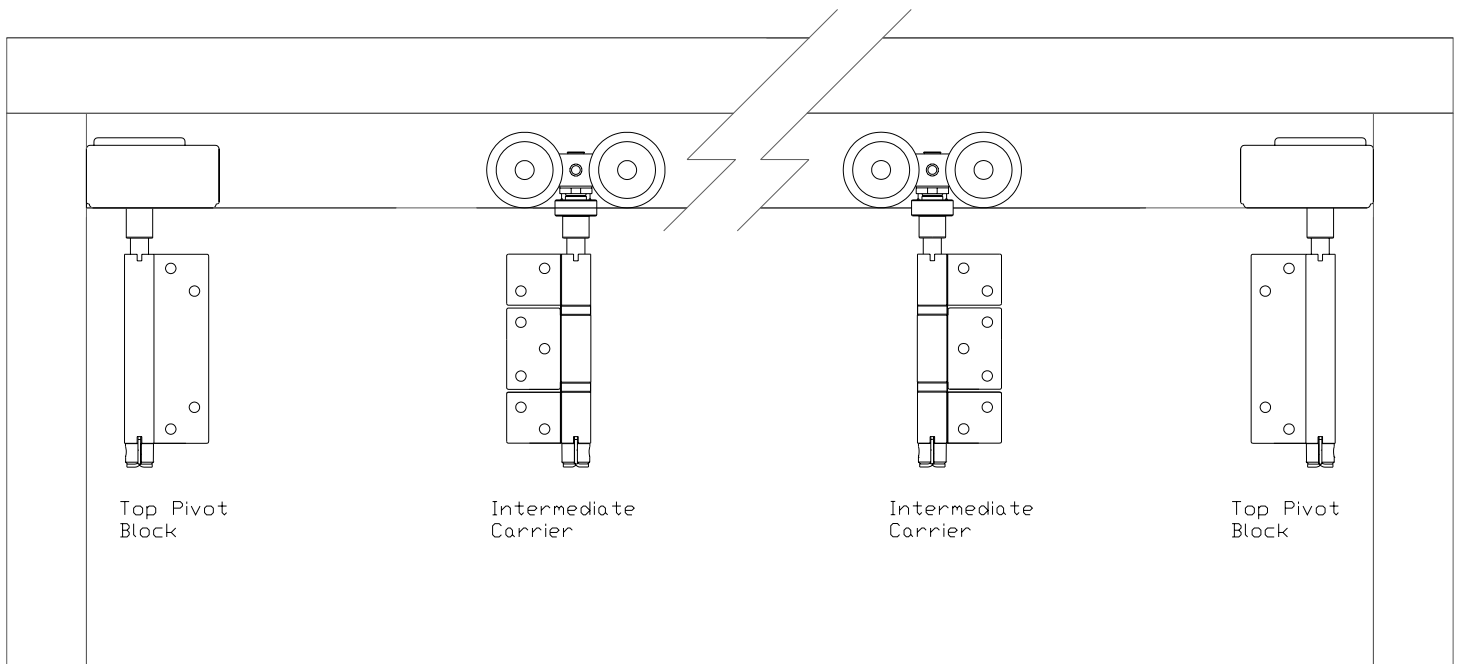

Hardware Orientation of Intermediate Carriers and Top Pivot Blocks.

FIT THE BOTTOM PIVOT

Fit the Bottom Pivots into the channel that is incorporated into the Frame Sill at both ends of the frame. Drill 4mm pilot holes into the sill channel to accept the 2 Pivot Block fixing screws. The Bottom Pivot position can be adjusted by rotating the Horizontal Adjustment Screw, (See **FIT BOLTED DOOR PANEL 1**)

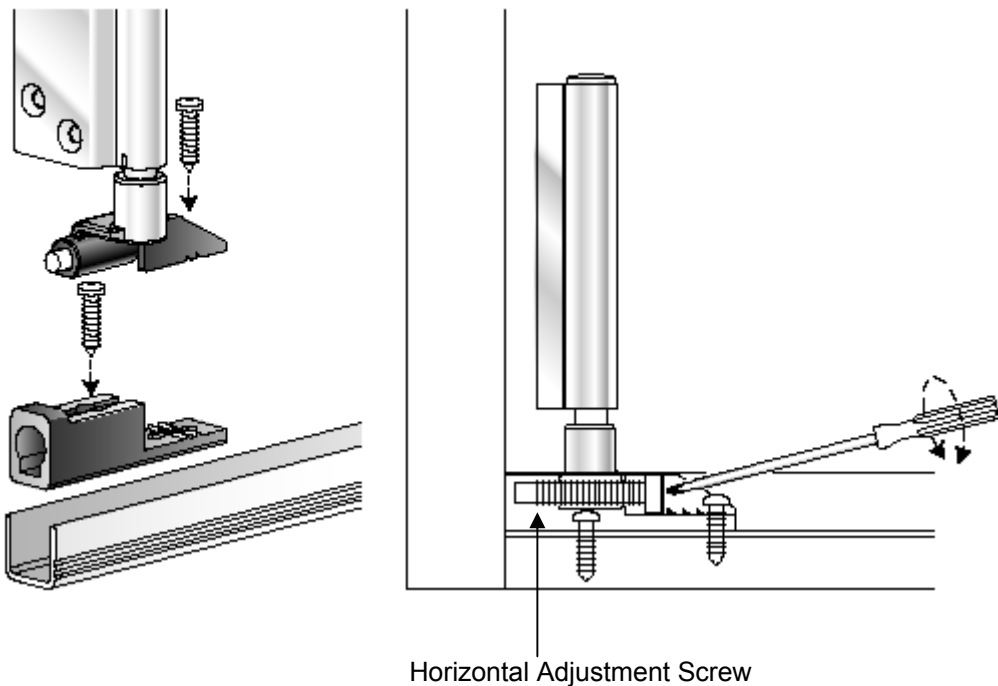

FIT THE WALL PIVOTS

The Wall Pivots require fitting as displayed below and are located on both Frame Jambs. The bore holes require drilling and will run completely through the jambs; therefore it is advisable to silicone inside the bore holes to protect the bare timber.

The bore hole is situated centrally in line with the Aluminium Top Track and 1055mm from the underside of the Aluminium Top Track to the centre of the bore hole.

Ensure that the Wall Pivot Hinge is located on the fixed hinge pin prior to fitting the door panels.

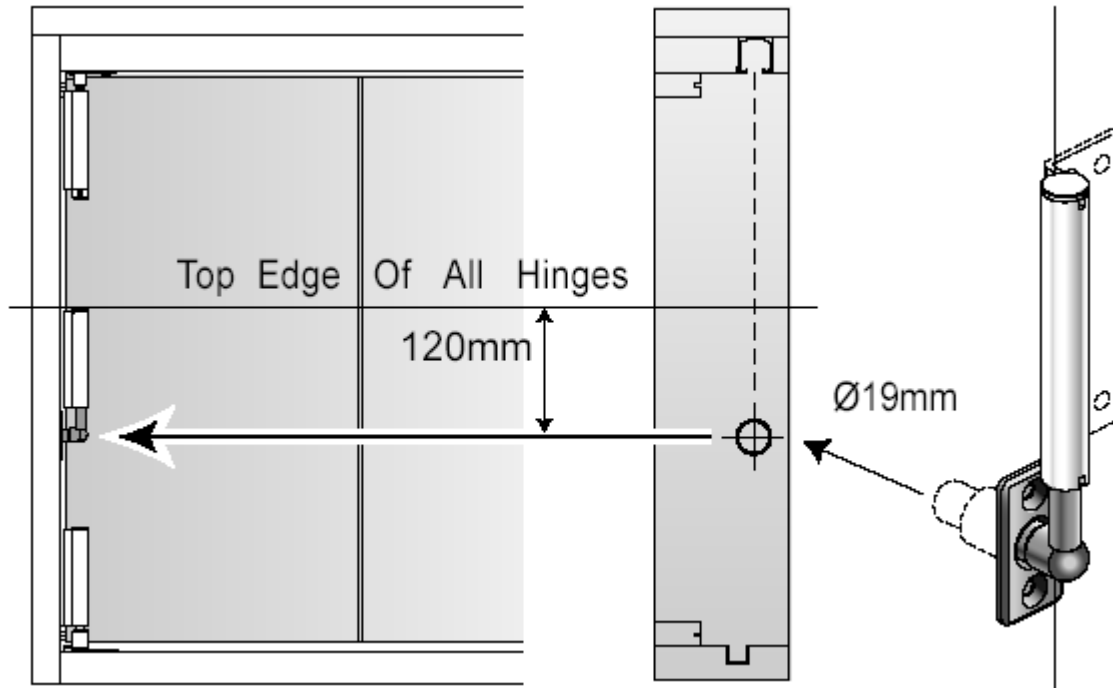

FIT BOLTED DOOR PANELS 1 & 4

- Fit Bolted Door Panel 1 by screwing the Concealed Pivot Set hinge flaps and Wall Pivot hinge flap to the door panel through the pre-drilled holes using the screws provided. Support the door panel with blocks and wedges to obtain the necessary height for hanging the door.
- Ensure the Drop Bolt Cut-outs are facing to the inside of the building.

Repeat this process for Bolted Door Panel 4 at the opposite end of the frame.

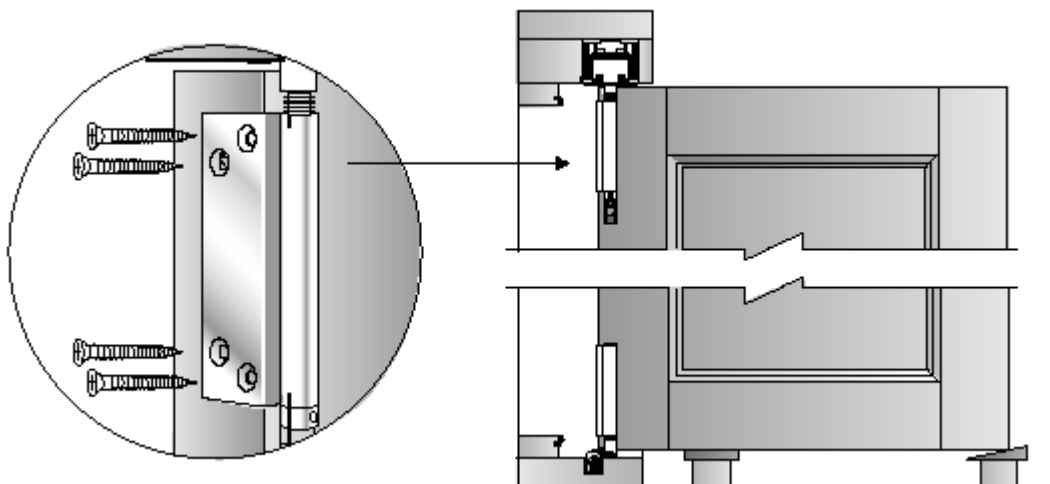

Adjust the door orientation to maintain an even gap between the door panel and the frame jamb. This is achieved by rotating the Horizontal Adjustment Screw in the Top Pivot Block and Bottom Pivot clockwise or anticlockwise. Ensure that the door panel is plumb after adjustment.

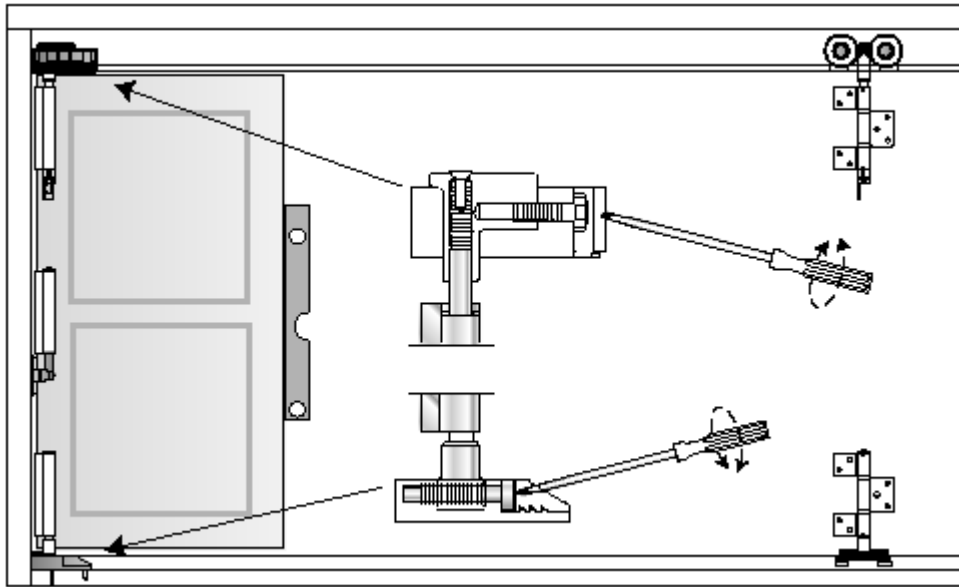

FIT BOLTED DOOR PANEL 2 & BOLTED DOOR PANEL 3

- Fit the Half Offset Hinge Set to Bolted Door Panel 1, pre-drilling 4mm holes and ensuring the handle points to the inside of the building. Remember to leave a 1mm gap between all the hinge barrels and the face of the door.
- Screw Bolted Door Panel 2 to the Half Offset Hinge Set through the pre-drilled holes, again using blocks and wedges to support the door panel.
- Ensure the Drop Bolt cut outs are facing to the inside of the building.
- Screw the Intermediate Carrier Set to Bolted Door Panel 2, pre-drilling 4mm holes and ensuring the Intermediate Carrier Set Guide sits within the frame sill channel.
- All doors must line up evenly with each other.

Repeat this process for Bolted Door Panel 3 at the other end of the frame.

FIT BOLTED DOOR PANEL KEEP

- Screw the Bolted Door Panel Keep to the Intermediate Carrier Set through the pre-drilled holes, again using blocks and wedges to support the door panel.
- The Bolted Door Panel Keep will be fitted to either Bolted Door Panel 2 or 3 depending on the Locking Door Panel Orientation.
- Ensure the Drop Bolt cut outs are facing to the inside of the building.

FIT LOCKING DOOR PANEL 1

- Screw Locking Door Panel 1 to the Intermediate Carrier Set through the pre-drilled holes, again using blocks and wedges to support the door panel.
- Locking Door Panel 1 will be fitted to either Bolted Door Panel 2 or 3 depending on the Locking Door Panel Orientation.
- Ensure that the pinned glazing beads of the Locking Door Panel face to the inside of the building.
- All doors must line up evenly with each other.

HARDWARE & PANEL ORIENTATION

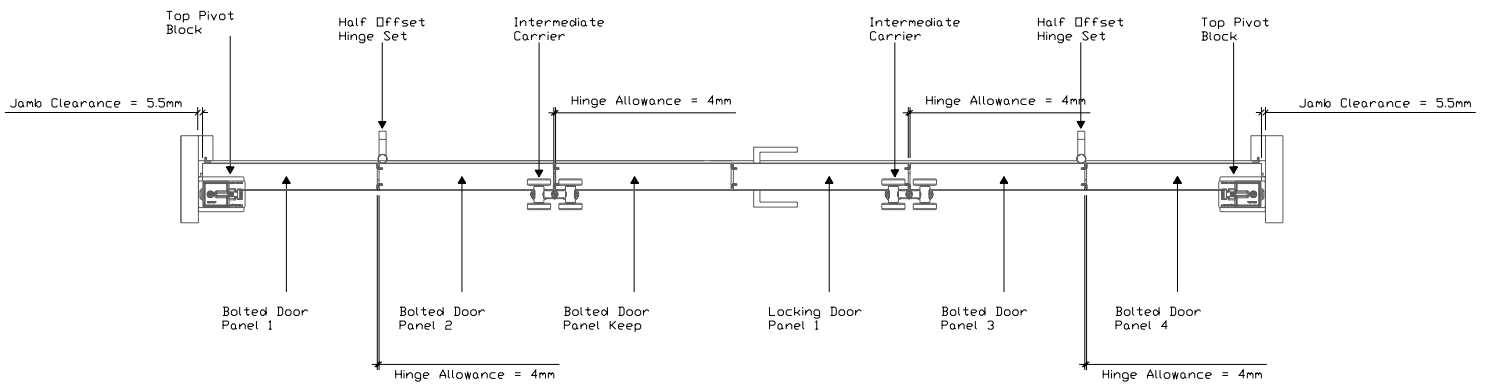

Right Hand Opening Locking Door Panel Displayed Above

FINAL ADJUSTMENT OF THE DOORS

Further adjustment of the Top Pivot Blocks and Bottom Pivots can be made to space the door panels correctly across their width.

The height of the door can be adjusted by rotating the hinge pin in the Intermediate Carrier and Top Pivot Block. The height should be adjusted so that there is an even **5mm gap** between the top of the doors and the underside of the Aluminium Top Track. This is achieved as follows:

1. Insert a flat-bladed screwdriver into the slot and rotate the pin.
2. When correct adjustment is reached remove the shipping clip.
3. The locking clip will snap into place when the blade and slot are aligned.
4. To readjust pull the locking clip down to disengage it from the slot, replace the shipping clip and rotate the pin.
5. Remove shipping clip after final installation adjustment.

ADJUSTING THE HEIGHT OF THE DOOR PANELS

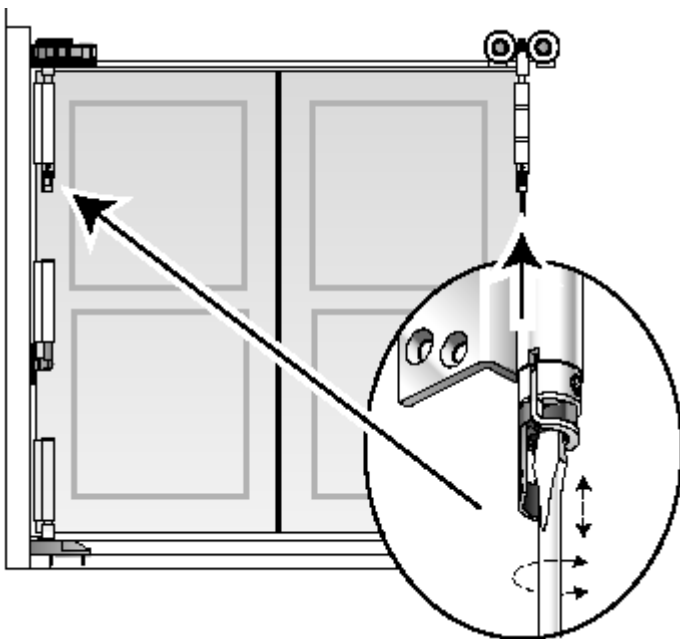

REMOVING THE SHIPPING CLIP

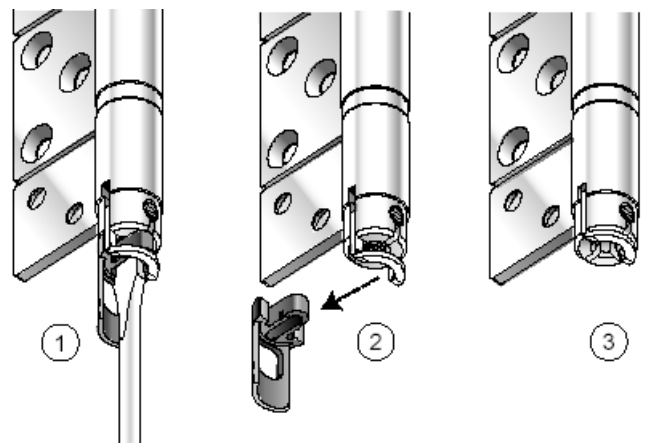

FIT THE WEATHER SEALS

Once the doors panels are in position fit the frame and door panel weather seals into the pre-machined grooves as displayed below. Ensure that the Aquamac 21 weather seals are butt jointed in the frame rebate where they meet between the jambs and head/ sill components.

DOOR PANEL & FRAME WEATHER SEALS

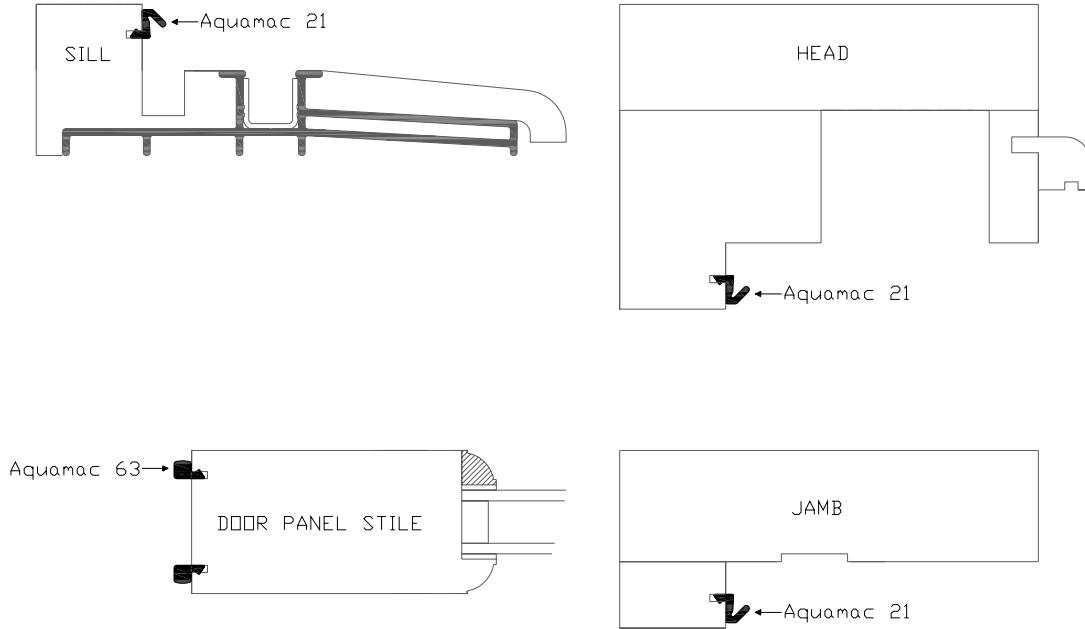

FIT FRAME HEAD DRIP BEAD

The Frame Head Drip Bead will require cutting out at both ends as displayed below so that it extends to the outside edges of the Frame Jamb. Silicone the inside of the pre-machined groove in the frame Head to fit the Bead and pin in place using 30mm Oval Headed Nails, (not supplied).

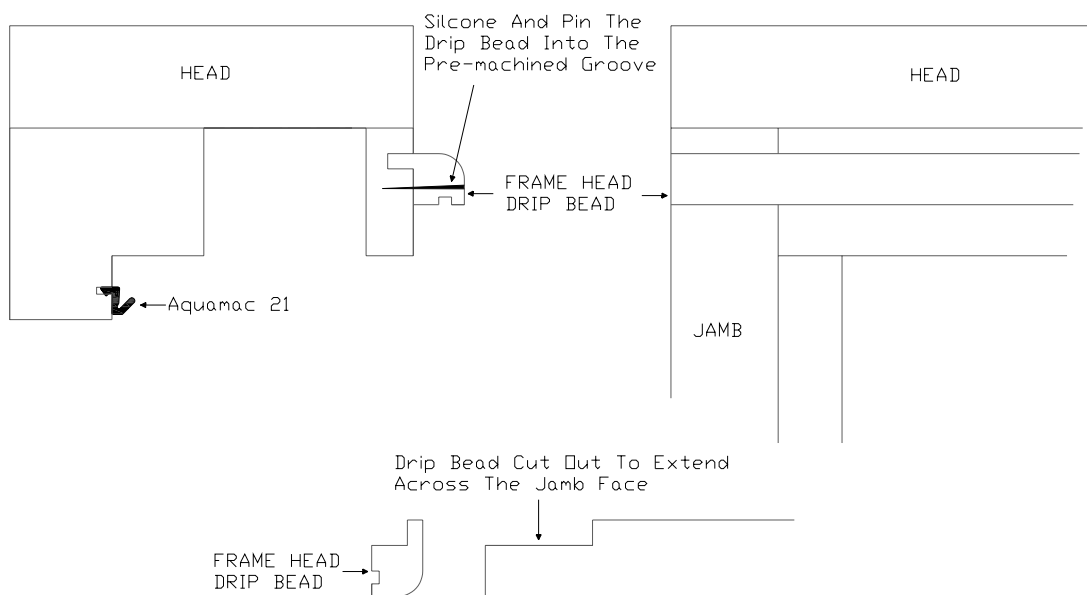

FIT THE DOOR PANEL BOLTS

The Bolted Door Panels and Bolted Door Panel Keep are pre-machined to accept the Drop Bolts. The Non-Keyed Drop Bolts are fitted to the top of the door panel and the Keyed Drop Bolts are fitted to the bottom of the door panels.

The Frame Head and Sill will require drilling and cutting out to accept the Drop Bolt shoot bolts, Drop Bolt Keepers and Striker Plates as displayed below. The Drop Bolt Keeper and Striker Plates will need the screw holes pre-drilling with a 3mm drill bit.

Ensure that the final adjustment of the doors is completed prior to cutting out for these items as this dictates the positioning of the Striker Plate and Drop Bolt Keeper.

To facilitate fixing of the keeps the Aquamac 21 weather seals can be temporarily removed from the Frame Head and Sill: Remember to replace these after the keeps are fitted.

It is recommended that the cut outs are coated with silicone prior to final fitting of the Drop Bolt Keepers and Striker Plates to ensure that there is no moisture ingress.

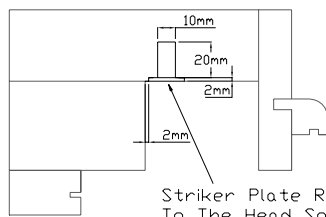

STRIKER PLATE

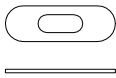

NON-KEYED DROP BOLT

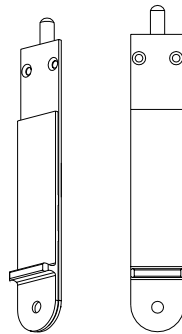

DROP BOLT CUT OUTS

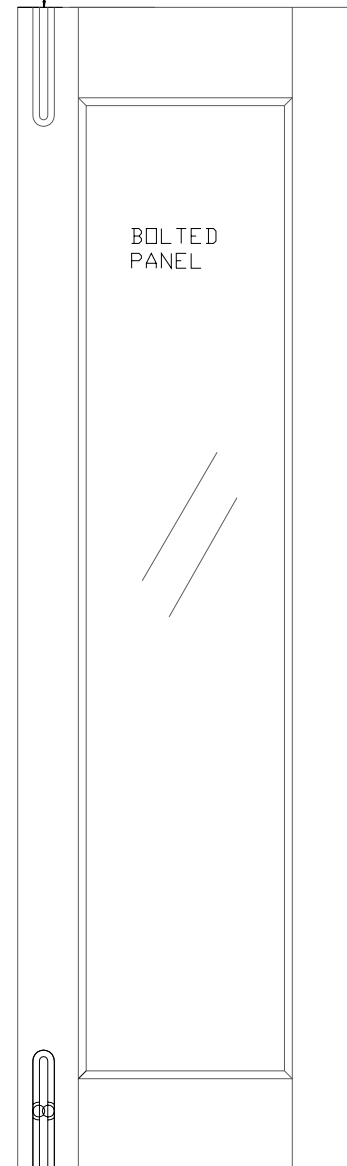

DROP BOLT KEEPER

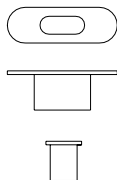

Drop Bolt Keeper Requires Countersinking Into The Sill So That The Top Face Sits Proud Of The Surface

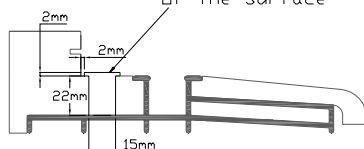

KEYED DROP BOLT

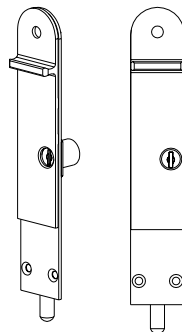

DROP BOLT CUT OUTS

FIT THE LOCK, KEEPS & HANDLES

FIT THE MULTI-POINT LOCK & HANDLES

The Locking Door Panel is cut out to receive the Multi-Point Lock:

- Carefully mark on the Locking Door Panel the position of the Handle Spindle, Keyhole and Handle retaining screws and drill through the door stile: The top and bottom of the Multi-Point Lock will line up with the top and bottom of the Locking Door Panel.
- Insert the Multi-Point Lock into the pre-machined cut-out and screw it in place using the 30mm screws provided.
- Insert the handle spindle through the drilled hole and attach the handles to the door, securing with the handle retaining screws: The handle retaining screws will need trimming to length to suit door thickness.
- If necessary reverse the Multi-Point Lock sash bolt so that the curved face closes towards the Frame Jamb.

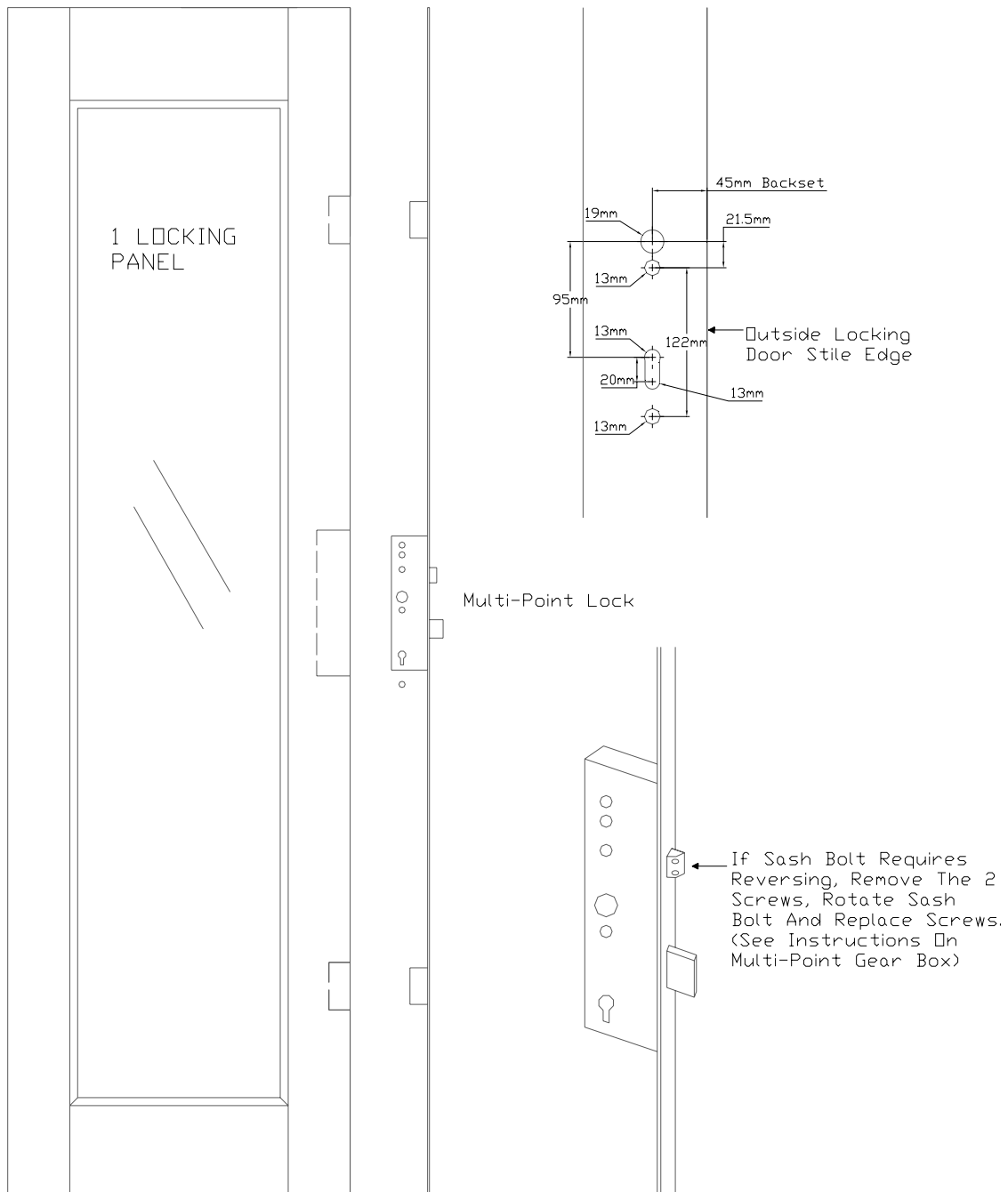

FIT THE ONE PIECE LOCK KEEP & ONE PIECE BLANK KEEPS

The Frame Jamb and Door Panel stiles are grooved to house the One Piece Blank Keeps and One Piece Lock Keep:

- Fix the One Piece Lock Keep to the Bolted Door Panel Keep adjacent to the Locking Door Panel with the 30mm screws provided: Ensure that the Multi-Point Lock, sash bolt and hooks line up vertically with the One Piece Lock Keep cut-outs.
- Ensure the Raised Bump of the One Piece Lock Keep is situated to the outside face of the Frame Jamb. If necessary the Raised Bump can be filed down until the door closes and the Multi-Point Lock sash bolt engages firmly.
- Fix the One Piece Blank Keeps to each Frame Jamb with the 30mm screws provided ensuring they are set at the same height as the One Piece Lock Keep.

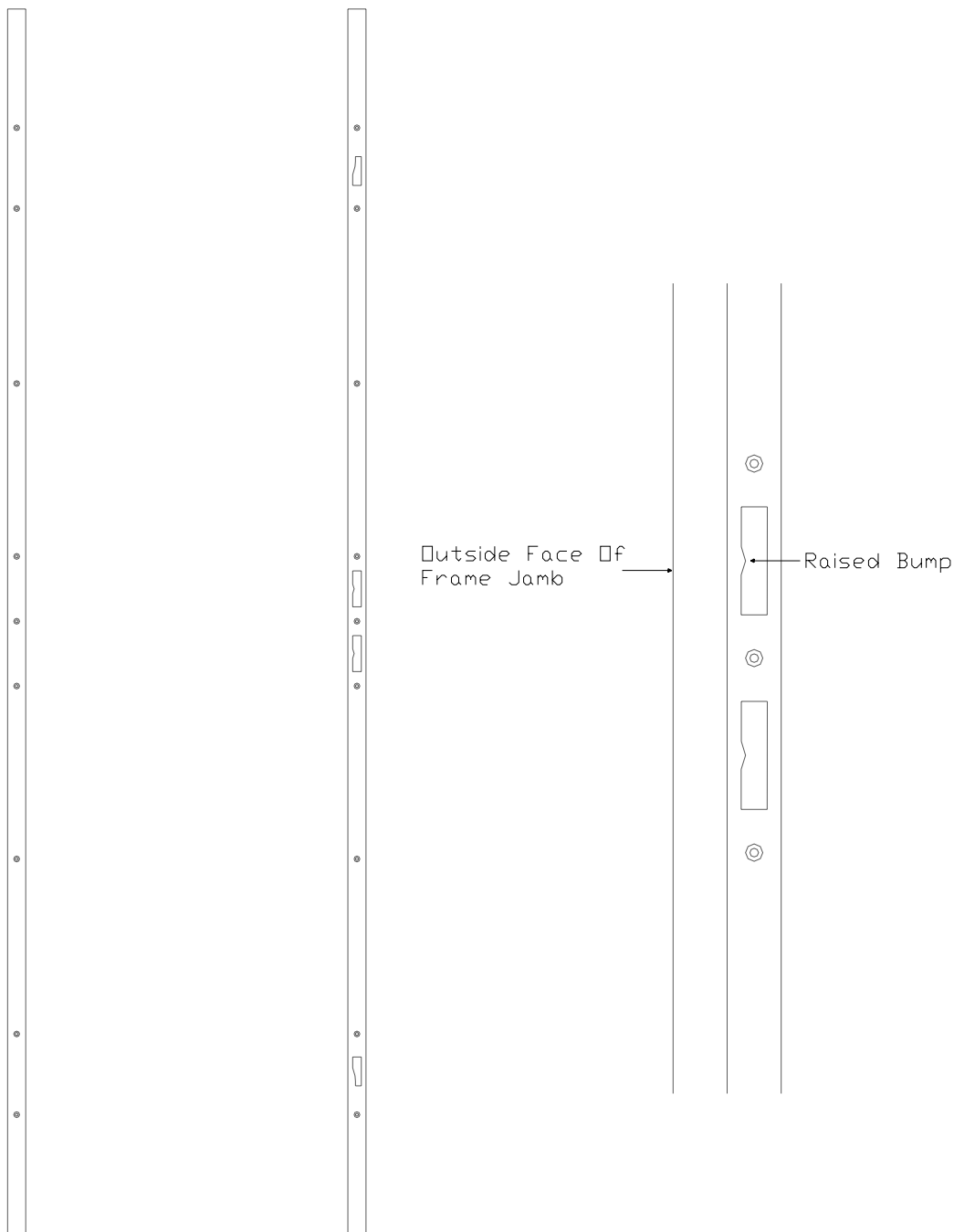

One Piece Blank Keep

One Piece Lock Keep